

Table D-57.6 - Grinding and Polishing Belts

Belts width inches (cm.)	Exhaust volume (ft. ³ /min.)
Up to 3 (7.62)	220
Over 3 to 5 (7.62 to 12.7)	300
Over 5 to 7 (12.7 to 17.78)	390
Over 7 to 9 (17.78 to 22.86)	500
Over 9 to 11 (22.86 to 27.94)	610
Over 11 to 13 (27.94 to 33.02)	740

§1926.57

(g)(3)(viii) *Cradles and swing-frame grinders.* Where cradles are used for handling the parts to be ground, polished, or buffed, requiring large partial enclosures to house the complete operation, a minimum average air velocity of 150 feet per minute shall be maintained over the entire opening of the enclosure. Swing-frame grinders shall also be exhausted in the same manner as provided for cradles. (See fig. D-57.3)

(ix) *Where the work is outside the hood, air volumes must be increased as shown in American Standard Fundamentals Governing the Design and Operation of Local Exhaust Systems, Z9.2-1960 (section 4, exhaust hoods).*

(4) *Exhaust systems.*

(i) *Exhaust systems for grinding, polishing, and buffing operations should be designed in accordance with American Standard Fundamentals Governing the Design and Operation of Local Exhaust Systems, Z9.2-1960.*

(ii) *Exhaust systems for grinding, polishing, and buffing operations shall be tested in the manner described in American Standard Fundamentals Governing the Design and Operation of Local Exhaust Systems, Z9.2-1960.*

(iii) *All exhaust systems shall be provided with suitable dust collectors.*

(5) *Hood and enclosure design.*

(i) [A] *It is the dual function of grinding and abrasive cutting-off wheel hoods to protect the operator from the hazards of bursting wheels as well as to provide a means for the removal of dust and dirt generated. All hoods shall be not less in structural strength than specified in the American National Standard Safety Code for the Use, Care, and Protection of Abrasive Wheels, B7.1-1970.*

[B] *Due to the variety of work and types of grinding machines employed, it is necessary to develop hoods adaptable to the particular machine in question, and such hoods shall be located as close as possible to the operation.*

(ii) *Exhaust hoods for floor stands, pedestals, and bench grinders shall be designed in accordance with figure D-57.2. The adjustable tongue shown in the figure shall be kept in working order and shall be adjusted within one-fourth inch (0.635 cm) of the wheel periphery at all times*

(iii) *Swing-frame grinders shall be provided with exhaust booths as indicated in figure D-57.3*

(iv) *Portable grinding operations, whenever the nature of the work permits, shall be conducted within a partial enclosure. The opening in the enclosure shall be no larger than is actually required in the operation and an average face air velocity of not less than 200 feet per minute shall be maintained.*

(v) *Hoods for polishing and buffing, and scratch-brush wheels shall be constructed to conform as closely to figure D-57.4 as the nature of the work will permit.*

(vi) *Cradle grinding and polishing operations shall be performed within a partial enclosure similar to figure D-57.5. The operator shall be positioned outside the working face of the opening of the enclosure. The face opening of the enclosure should not be any greater in area than that actually required for the performance of the operation and the average air velocity into the working face of the enclosure shall not be less than 150 feet per minute*

(vii) *Hoods for horizontal single-spindle grinders shall be constructed to conform as closely as possible to the hood shown in figure D-57.6. It is essential that there be a space between the back of the wheel and the hood, and a space around the periphery of the wheel of at least 1 inch (2.54 cm) in order to permit the suction to act around the wheel periphery. The*

§1926.57

(g)(5)(vii) opening on the side of the disc shall be no larger than is required for the grinding operation, but must never be less than twice the area of the branch outlet.

(viii) *Horizontal double-spindle disc grinders shall have a hood encircling the wheels and grinding chamber similar to the illustrated in figure D-57.7. The openings for passing the work into the grinding chamber should be kept as small as possible, but must never be less than twice the area of the branch outlets.*

(ix) *Vertical-spindle disc grinders shall be encircled with a hood so constructed that the heavy dust is drawn off a surface of the disc and the lighter dust exhausted through a continuous slot at the top of the hood as shown in figure D-57.1.*

(x) *Grinding and polishing belt hoods shall be constructed as close to the operation as possible. The hood should extend almost to the belt, and 1-inch (2.54 cm) wide openings should be provided on either side. Figure D-57.8 shows a typical hood for a belt operation.*

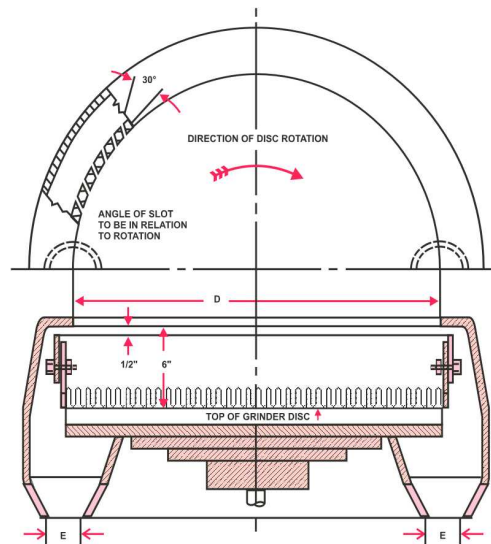

FIGURE D-57.1 - Vertical Spindle Disc Grinder Exhaust Hood and Branch Pipe Connections

Diameter D, inches (cm.)		Exhaust E		Volume exhausted at 4,500 ft./min. ft. ³ /min.	Note
Min.	Max.	No. pipes	Dia.		
-	20 (50.8)	1	4 1/4 (10.795)	500	When 1/2 or more of the disc can be hooded, use exhaust ducts as shown at left
Over 20	30 (76.2)	2	4 (10.16)	780	
Over 30	72 (182.88)	2	6 (15.24)	1,770	
Over 53	72 (182.88)	2	8 (20.32)	3,140	When no hood can be used over disc, use exhaust ducts as shown at left
-	20 (50.8)	2	4 (10.16)	780	
Over 20	20 (50.8)	2	4 (10.16)	780	
Over 30	30 (76.2)	2	5 1/2 (13.97)	1,480	
Over 53	53 (134.62)	4	6 (15.24)	3,530	
	72 (182.88)	5	7 (17.78)	6,010	

Entry loss = 1.0 slot velocity pressure + 0.5 branch velocity pressure.
Minimum slot velocity = 2,000 ft/min - 1/2 inch (1.27 cm) slot width.